

**MOTOROLA
SEMICONDUCTOR**

MC33198

Automotive High Side TMOS Driver

**HIGH SIDE
TMOS DRIVER**

**SILICON MONOLITHIC
INTEGRATED CIRCUIT**



D SUFFIX
PLASTIC PACKAGE
CASE 751-02
SO-8

The MC33198D is a high side TMOS driver, dedicated for automotive applications. It is used in conjunction with an external power MOSFET for high side drive applications. The device can drive and protect a large variety of MOSFET. The device has CMOS compatible input control, charge pump to drive the MOSFET gate, fault detection circuitry based on programmable Vds monitoring to detect shorted load. It also includes a programmable timer function to eliminate undesired switch off due to inrush currents and a status pin which reports the output status in both on and off MOSFET state. The device uses few external components and offers an economical solution to large current high side switch. It also has PWM capability up to 1kHz.

- Designed for Automotive High Side Driver Application
- Works with a Wide Variety of N-Channel Power MOSFETs
- PWM Capability
- On Board Charge Pump Capable of Charging 25nF in less than 1ms with No External Components Required
- Drive Inductive Load with No External Clamp Circuitry Required
- CMOS Logic Compatible Input Control
- TMOS Over Current and Short Circuit Protection
- Fault Output to Report an Over MOSFET Current Condition
- Output Status Available when MOSFET is On or Off
- Extended Temperature Range from -40°C to 125°C
- Protected Against Automotive Transients with few External Components
- Over Voltage and Under Voltage Shutdown

PIN ASSIGNMENT

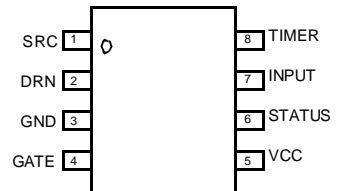

ORDERING INFORMATION

Device	Temperature Range	Package
MC33198D	- 40°C to +125°C	SO8

Block Diagram and Typical Application

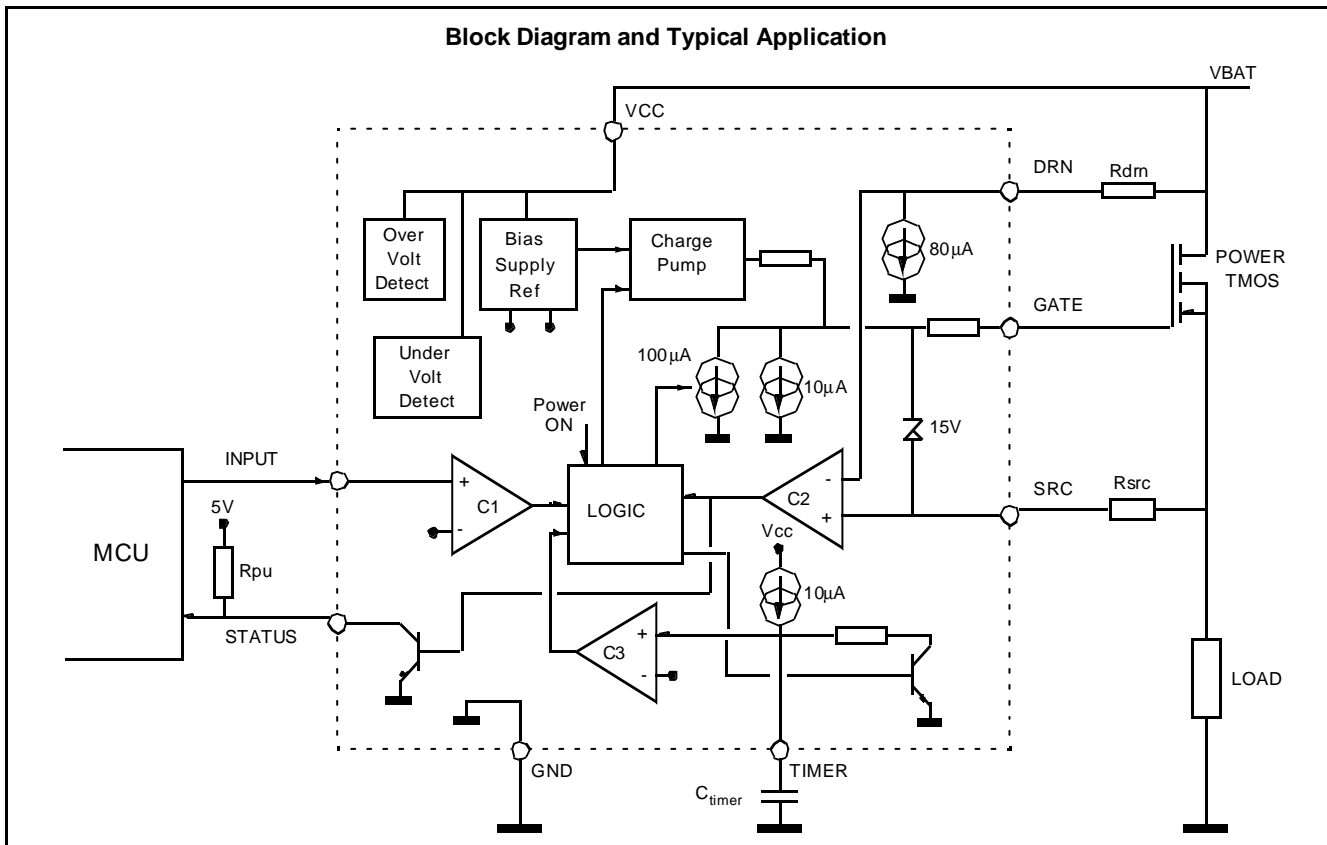

MAXIMUM RATINGS

Ratings	Symbol	Value	Unit
---------	--------	-------	------

ELECTRICAL RATINGS

Power Supply Voltage (Pin 5)	V _{cc}	-0,6 to 60	V
TMOS Source Voltage (Pin 1)	V _{src}	-0,6 to 60	V
Comparator Threshold (Pin 2)	V _{dm}	-0,6 to 60	V
Gate Output Voltage (Pin 4)	V _{gate}	-0,6 to 25	V
Input Voltage (Pin 7)	V _{in}	-0,6 to 25	V
Status (Pin 6)	V _{st}	-0,6 to 10	V
ESD Voltage Capability	V(ESD)	+/-2000	V

THERMAL RATINGS

Storage Temperature	T _{stg}	-55 to +150	°C
Operating Junction Temperature	T _j	-40 to +150	°C
Thermal Resistance J/A	R _j	145	°C

ELECTRICAL CHARACTERISTICS. T_{amb} from -40°C to +125°C, V_{cc} from 7V to 20V, unless otherwise note. Typical values reflect approximate mean at 25°C, nominal V_{CC}, at time of device characterization.

Parameters	Symbol	Min	Typ	Max	Unit
------------	--------	-----	-----	-----	------

SRC Pin 1

Leakage Current	I _{lsrc}	-10		10	μA
-----------------	-------------------	-----	--	----	----

DRN Pin 2

Threshold Current	I _{thr}	54	81	102	μA
DRN Leakage, Input Off, V _{cc} Pin Open	I _{leak}			10	μA

GATE Pin 4

Output On Voltage at 1ms (Charge Pump ON)	V _{on}	V _{cc} + 7		V _{cc} +15	V
Turn Off Current - with NO Over V _{ds} condition and V _{out} > 0.5V - with Over V _{ds} condition and V _{out} > 0.5V	I _{outn} I _{outw}	70 5	110 10	150 15	μA μA
Output Off Voltage. (Charge Pump OFF and V _{cc} Pin Open)	V _{off}	0		0.9	V
Gate Discharge Current. (V _{cc} Pin Open)	I _{off}		5		μA
Turn On Time - C _l = 25nF ; 7V < V _{cc} < 10V ; V _{out} > V _{cc} +7 - C _l = 25nF ; 10V < V _{cc} < 20V ; V _{out} > V _{cc} +10	t _{on}			1 1	ms

VCC Pin 5

Supply Voltage Range	V _{cc}	7		20	V
Quiescent Supply Current ; I _n = 0V - at V _{cc} = 7V - at V _{cc} = 20V	I _{ccq}		1.8 2.8	4 6	mA
Supply Current ; I _n = 5V	I _{cc}	1		35	mA
Over Voltage Threshold	V _{ov}	22	28	34	V
Under Voltage Threshold	V _{ur}		6	7	V

ELECTRICAL CHARACTERISTICS. Tamb from -40°C to +125°C, Vcc from 7V to 20V, unless otherwise note. Typical values reflect approximate mean at 25°C, nominal VCC, at time of device characterization.

Parameters	Symbol	Min	Typ	Max	Unit
------------	--------	-----	-----	-----	------

STATUS Pin 6

Output Voltage @ I = 1mA	V _{ol}	0,1	0,4	1.5	V
--------------------------	-----------------	-----	-----	-----	---

INPUT Pin 7

Input Low Voltage	V _{il}			1.5	V
Input High Voltage	V _{ih}	3.5			V
Input Hysteresis	V _{hys}	0.8			V
Input Pull Down Resistor. Vin > 11V	R _{in}	20	36	100	kΩ
Open Input Voltage	V _{iop}			1	V

TIMER Pin 8

Timer Current	I _{time}	7	10	14	μA
On Threshold	V _{hth}	5.2	5.5	5.8	V
Discharge Current @ V _{pin8} = 5V	I _{disch}	2	5	10	mA
Saturation Voltage @ I _{pin8} = 1mA	V _{sat}		0,15	0.4	V

DYNAMIC ELECTRICAL CHARACTERISTICS

Parameters	Vcc = 7V	Vcc = 14V	Vcc = 21V	Unit
------------	----------	-----------	-----------	------

TYPICAL RISE TIME (t_r) versus Gate External Capacitor Load and Supply Voltage (refer to figure 1)

C = 1nF	15	7	10	μs
C = 3nF	60	25	40	μs
C = 10nF	140	80	90	μs
C = 30nF	730	270	340	μs

TYPICAL FALL TIME (t_f) versus Gate External Capacitor Load and Supply Voltage (refer to figure 1)

C = 1nF	150	230	280	μs
C = 3nF	430	800	950	μs
C = 10nF	1200	2300	2750	μs
C = 30nF	4800	8000	9200	μs

Figure1. Timing Measurement Test Schematic

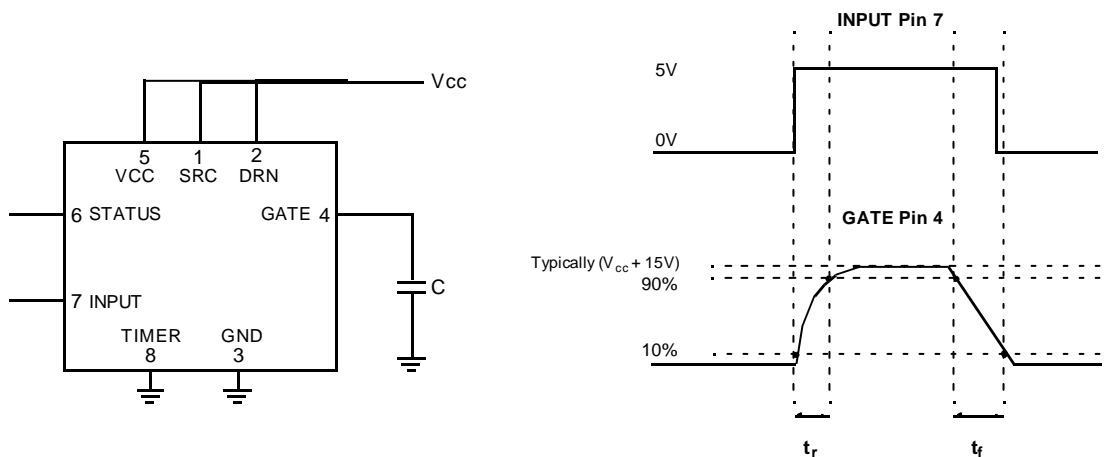

Figure2. Supply Current versus Supply Voltage. Pin 7 = 0V

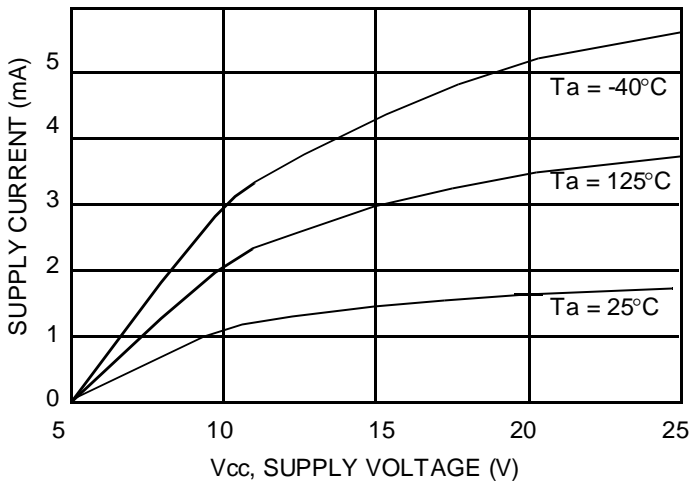

Figure3. Supply Current versus Supply Voltage. Pin 7 = 5V

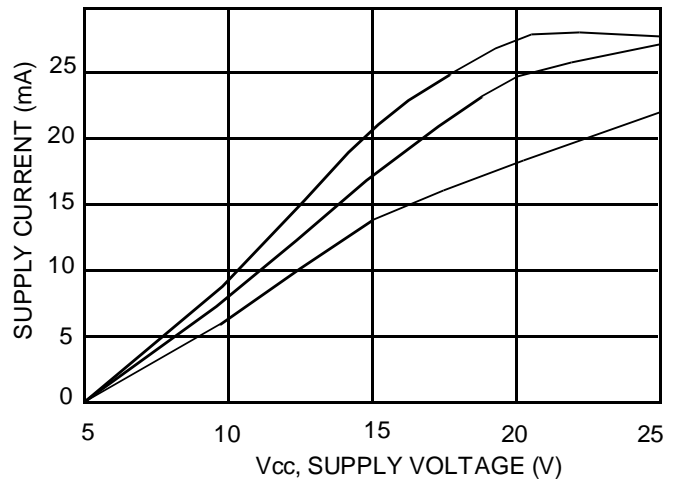

Figure4. Time Current versus Supply Voltage

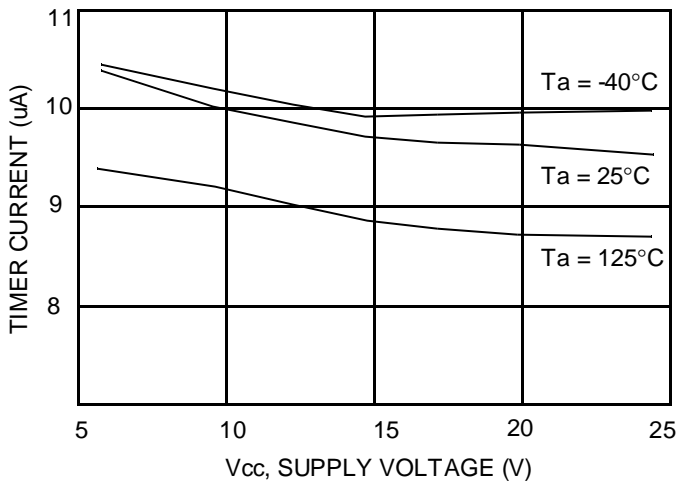

Figure5. Drain Current versus Supply Voltage

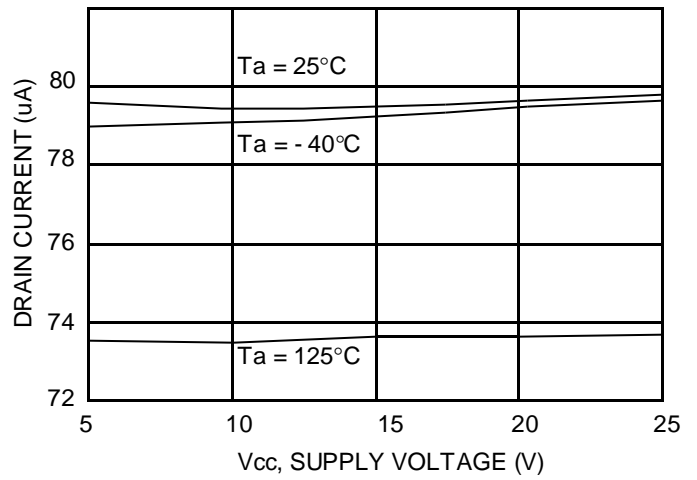

Figure6. Fault Output Voltage versus Current

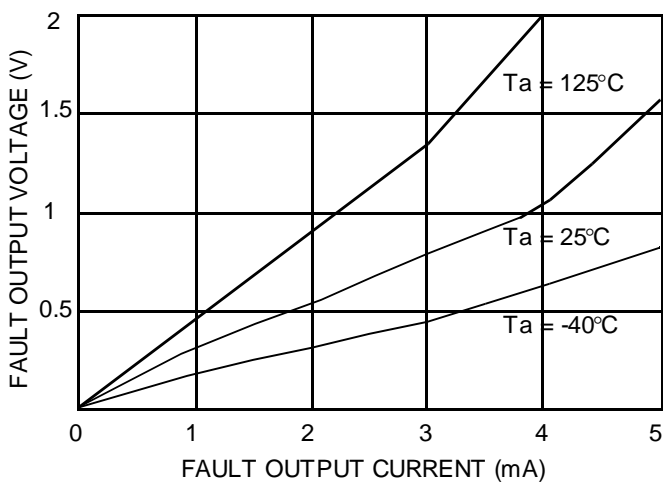

Figure7. Gate Voltage versus Voltage

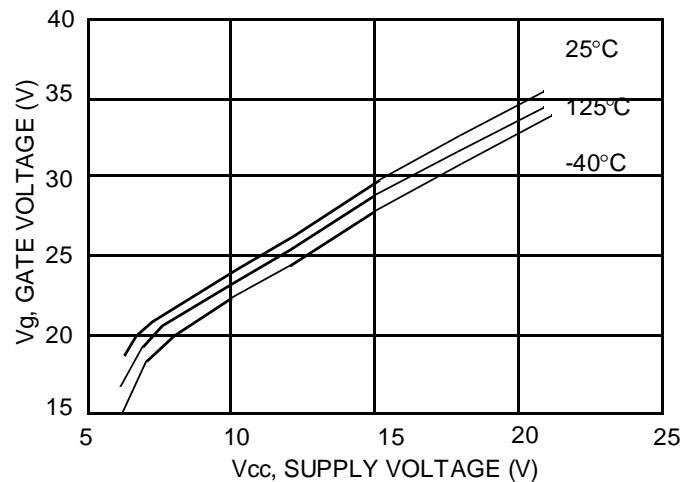

Figure8. Gate Voltage versus Gate Output Current. Ta = 25°C.

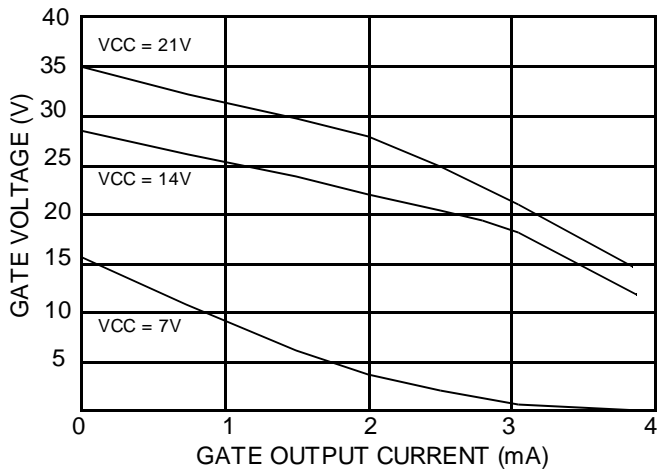

Figure9. Gate Voltage versus Gate Output Current. Ta = 125°C

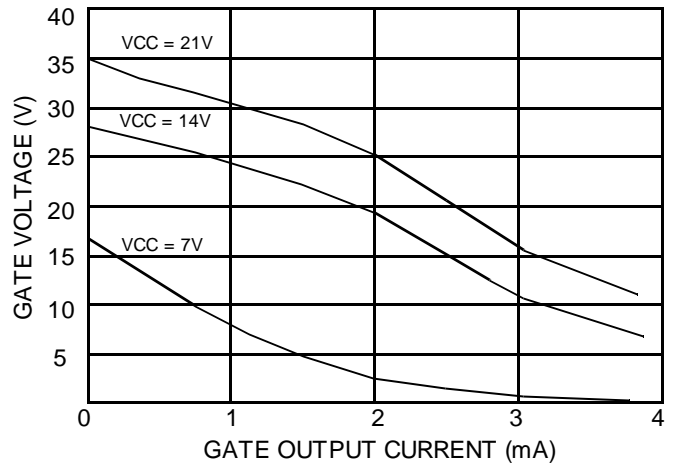

Figure10. Gate Voltage versus Gate Output Current. Ta = 40°C

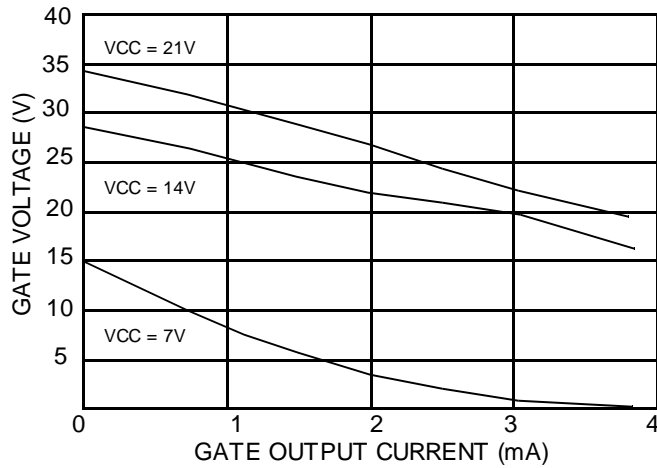

Figure11. Gate Voltage versus Vcc and Rg at Ta = 25°C

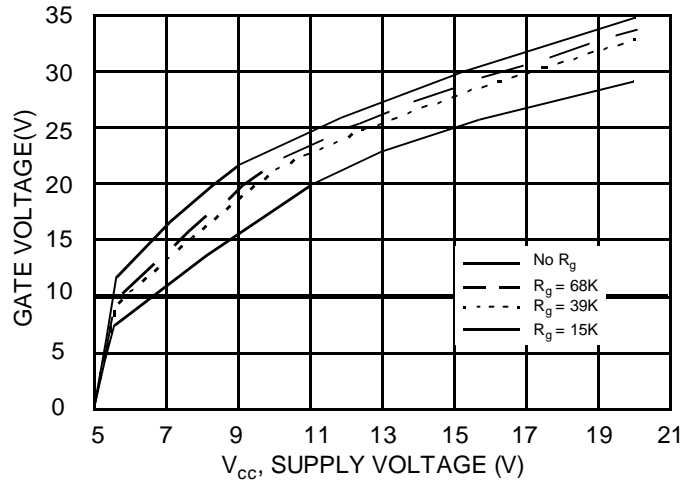
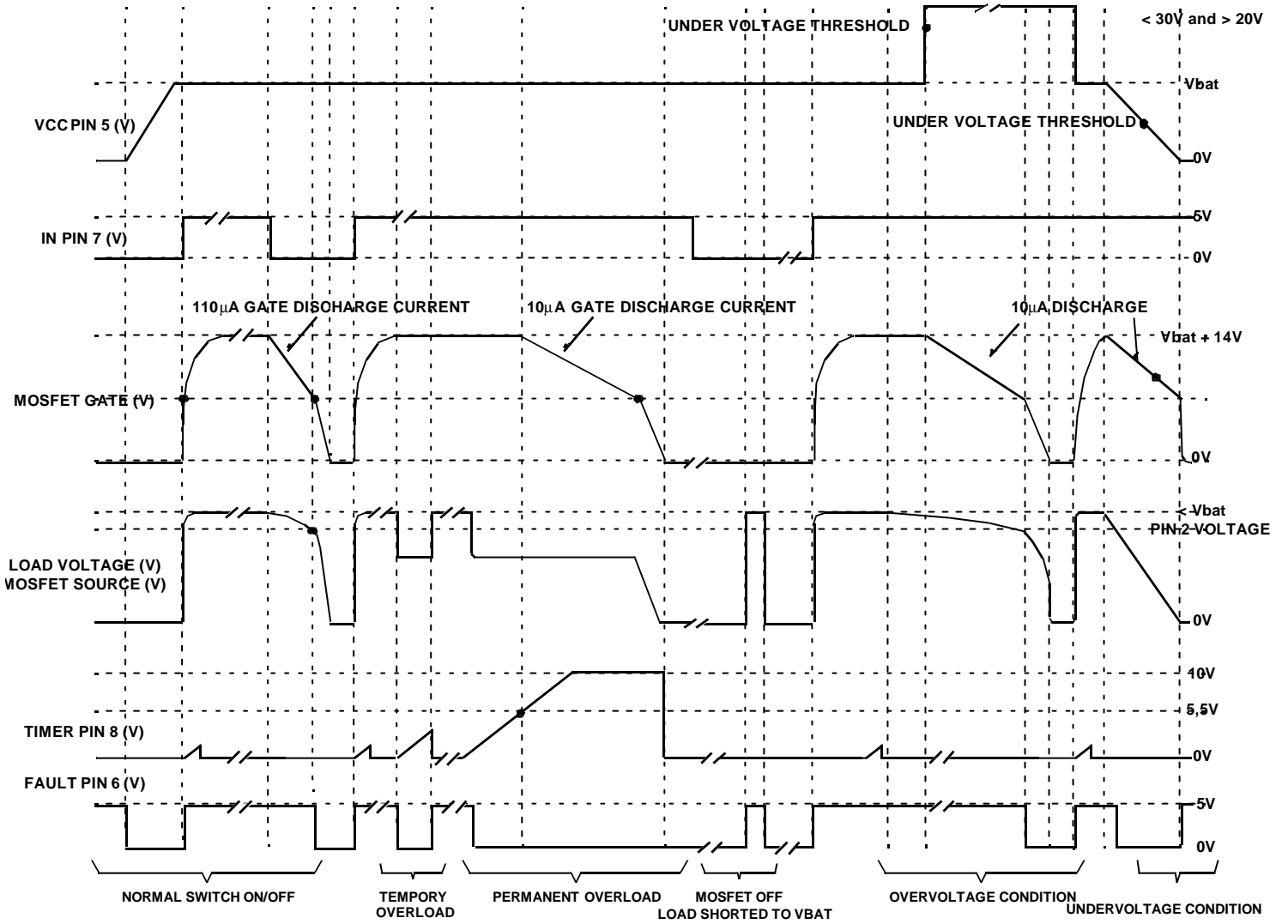

Figure 12. Descriptive Waveform Diagram



DEVICE DESCRIPTION

Introduction

The MC33198D is a high side T MOS driver, dedicated for automotive applications. It is used in conjunction with an external power MOSFET for high side drive applications. The device can drive and protect a large variety of MOSFET. The device has CMOS compatible input control, charge pump to drive the MOSFET gate, fault detection circuitry based on programmable V_{ds} monitoring to detect shorted load. It also includes a programmable timer function to eliminate undesired switch off due to inrush currents and a status pin which reports the output status in both on and off MOSFET state. The device uses few external components and offers an economical solution to large current high side switch. It also has PWM capability up to 1kHz.

Power Supply

The MC33198D can be supplied from the battery line. It is designed in a 60V technology, making it able to sustain up to 60V transient pulses. In off state, with pin 7 low, the supply current is up to 5mA, and in operation, pin 7 high, the current up to 25mA. The device has an undervoltage detection and shutdown near 7V. Below this value the MOSFET is turned off. There is also a 25V overvoltage detection which switches off the output pin 4 to protect both MOSFET and load when V_{cc} is higher than 25V.

Charge Pump

The device incorporates a self running charge pump with internal capacitor and connected at Gate pin 4. To prevent oscillation, a serial resistor can be added. The charge pump is able to charge a 25nF capacitor in less than 1ms. This allows the MC33198D to have a rapid response time and to drive the external T MOS gate very quickly, allowing fast switching on of the load. The device has an internal 14V zener diode between pin 4 and 1 to clamp the Gate-to-Source voltage and protect the MOSFET gate oxide from destruction. See Dynamic Electrical Characteristics table for details.

Band Gap and Reference Currents

The MC33198D has an internal band gap reference voltage which generates all the internal thresholds. This band gap is also used to generate internal reference currents necessary for proper operation of the device.

These currents are :

Pin 2 : Drain current (typically 80μA).

Pin 4 : High and low gate discharge currents (typically 100μA and 10μA).

Pin 8 : Timer charge current (10μA typical).

All these currents are derived from the same reference voltage and internal resistor. Their accuracy and variability is approximately ±25% over the full temperature and voltage range. In addition, a passive pull down current of 5μA maintains the gate of the MOSFET below 0.9V when the device has no supply, ensuring that the MOSFET remains off. This passive pulldown current is operating even if device V_{cc} (pin 5) is not powered up.

Input Circuitry

The input of the device is CMOS compatible and can be directly connected to a microcontroller. The input current is determined by an internal pull down resistor of typically 36kΩ. A hysteresis of 0.8 V minimum is present at this input.

Output Status

The device has a status output (pin 6) which has an open collector structure. This pin is used to report the MOSFET over load condition or the LOAD status when MOSFET is off. The device Pin 1 (Source) is compared to a programmable threshold at Pin 2, in both on and off state of the MOSFET. This allows the detection of MOSFET over V_{ds} or over load conditions when MOSFET is on and load short to V_{bat} monitoring when MOSFET is in off state. This status pin is normally connected to a pull-up resistor and to a micro input and can drive up to 1mA. See below for detailed operation.

Timer

The timer (pin 8) is used in conjunction with an external capacitor to create a delay between the over load detection and the shutdown of the MOSFET. In case of over load, the internal current source pin 8 will charge the capacitor. When the voltage at pin 8 reaches the 5.5V threshold, the internal C3 comparator will be triggered and switch off the output to protect the MOSFET. The fault and the MOSFET turn off condition are latched and are reset by switching the input off and on. The delay between over load detection and actual MOSFET turn off is used to allow temporary over load which will prevent the system from switching off during possible inrush current or transients.

MOSFET Protection and Output Voltage Monitoring

The MC33198D has the ability to sense the output MOSFET source voltage and compare it to a predetermined threshold. This threshold is programmable using the internal reference current of 80μA and an external resistor connected at pin 2. The device can monitor the output load voltage, as well as protect the MOSFET in case of over load.

The over load detection threshold must be adapted to the MOSFET itself depending on the load to be driven and the thermal capability of the MOSFET. In practice, the maximum acceptable V_{ds} of the MOSFET should be determined and based upon MOSFET maximum power dissipation.

In addition, the pin 8 capacitor value should be calculated to allow inrush current.

Source (Pin1) and Drain (Pin2) Functionality

These two pins are used to sense the MOSFET and load conditions. Pin 2 is connected to the internal pull down current source of 80μA and to the C2 comparator. An external resistor connected between pin 2 and V_{bat} creates a voltage drop across this resistor. The voltage drop will be the MOSFET maximum acceptable drain to source voltage and the C2 comparator threshold.

Pin 1 is connected to the MOSFET source pin. Two different cases should be considered, MOSFET on or off :

When MOSFET is on and working in normal conditions, the Vds should be less than the voltage developed at pin 2. So, the C2 comparator output is low and the status is high. No current will flow through the pin 8 capacitor.

If the MOSFET encounters an over-load or if the load is shorted to Gnd, the voltage at the source will cross pin 2 voltage and go below this pin 2 voltage, thereby turning on the C2 comparator. The comparator will pull the status pin 6 low and will enable the charge of the pin 8 capacitor. When the voltage at the capacitor reaches 5.5V, the C3 comparator will switch off the MOSFET by disabling the charge pump and the 110µA current source. The MOSFET gate will be discharged only by the 10µA current source. The MOSFET is latched off and can be turned back on again by switching input pin 7 to 0 and back to 1.

When MOSFET is off, we have the same scheme.

In normal condition the load should pull the source voltage to Gnd, thus C2 comparator output is high and status pin pulled low. If the load is shorted to V_{bat} for instance, source pin will be higher than pin 2, C2 output comparator is low and status pin is high. This is summarized in the following table :

Table 1 • Status Functionality

Input	Condition	Source Load Voltage	C1 Output Comp	Fault Pin6	Timer Pin8
Low	Normal	< V _{pin2}	High	Low	Low
Low	Short circuit to V _{bat}	> V _{pin 2}	Low	High	Charge by 10µA source
High	Normal	> V _{pin 2}	Low	High	Low
High	Short to Gnd or Over load	< V _{pin2}	High	Low	Charge by 10µA source

Operation With Inductive Loads

The device can drive MOSFET in inductive loads switching applications. In this case, a 1kΩ resistor should be connected between source of the MOSFET and device pin 1. The resistor will limit the current flowing into pin 1 and prevent MC33198D from damage during switching off of the inductive load. The gate voltage is internally clamped at - V_{be} (0.6V typical), then the V_{ds} is limited to V_{bat} + V_{be} + V_{gson} to prevent excessive power dissipation in the MOSFET. The load voltage is limited to V_{be} + V_{gson} and allows reasonable discharge current.

Switching On

The switching on of the MOSFET is ensured by the internal charge pump. The charge pump response time versus the MOSFET gate capacitance is shown in table Dynamic Electrical Characteristic table .

Switching Off

Here two cases have to be discussed ; the normal switching off of the MOSFET and the switching off under fault condition. The normal switching off is done by internal pull down current sources. The value is 110µA and is in fact composed of two current sources in parallel ; a 100µA and a 10µA source. The 10µA current is always connected to the gate pin 4 as shown in device block diagram.

The 100µA source can be disabled. This is the case when the MOSFET is switched off under fault conditions. The device will disable the 100µA current source and the MOSFET gate will be discharged only by a 10µA current. The time required to switch off the MOSFET will be much longer in this case and will result in a lower over-voltage at the MOSFET, especially when the device drives high inductive loads.

Off State Operation without V_{cc} Connection

When pin 7 is in low state the MOSFET is off. If V_{bat} is present, the gate voltage is discharged by the 110µA current source. In the case of V_{bat} disconnection, a self sustaining 5µA pull down current source is incorporated in the device to ensure that the MOSFET gate capacitor is discharged and tied below 0.9V. In case of V_{cc} disconnection, input pin 7 has no effect on gate voltage which is maintained below 0.9V and in this case, status pin is high. Low leakage current at pin 2 (10µA max) allows operation with MOSFET and MC33198D pin 2 permanently connected to battery. V_{cc} and other functions can be switched off from the main battery line. See figure 15.

PWM Operation

Since the MC33198D charge pump can deliver a high current, the MOSFET gate can be charged fast enough to allow PWM operations. The maximum PWM frequency is dependent on the MOSFET itself and mainly its gate to source capacitor value. Depending on the PWM frequency, the switching off time can be long, compared to the on-switching time response. This is due to the 110µA gate discharge current. To improve this parameter, a resistor can be added in parallel with the gate of the MOSFET. See figures 13 and 14 below.

Figure13.

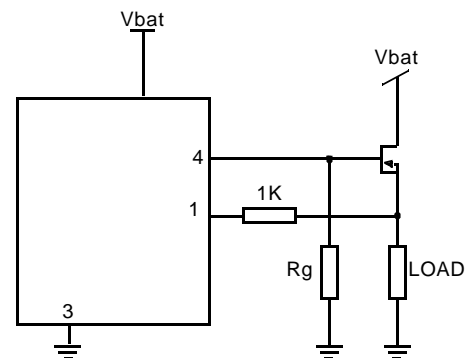
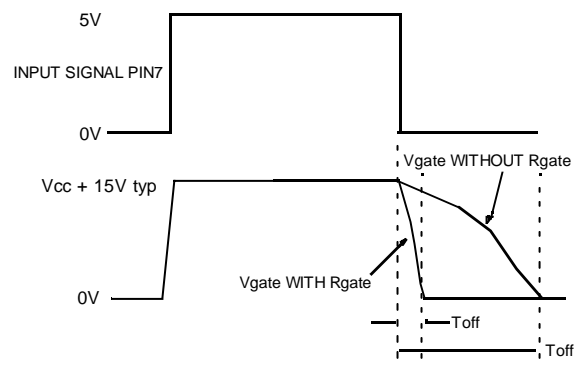

Figure14.



This resistor will reduce in some way the charge pump output voltage available for the MOSFET, but the device will still provide enough Gate-to-Source voltage to maintain the MOSFET on in good conditions. The resistor will mainly act as an additional discharge current, which will reduce the switching off time of the overall application. See the table 2 below and figure 11 which show the pin 4 voltage depending on the additional gate resistor and the off switching time due to this resistor.

If a very low switching time is needed, the resistor has to be extremely low, resulting in low gate voltage not high enough to ensure proper MOSFET operation. In this case, a logic level MOSFET can be used. Logic level will operate with Vgs of 5V with the same performance as a standard MOSFET having a 12V Vgs. Care should be taken regarding maximum gate to source voltage of a logic level MOSFET. An additional zener might be necessary to prevent gate oxide damages.

Table 2 • Switching Off Characteristics with MOSFET Additional Gate Resistor

Rgate	VCC (V)	Vgate (V)	Toff
No R	7	16	450
	10	23	700
	14	28	750
	20	34	780
68 kΩ	7	14	160
	10	22	230
	14	27	230
	20	33	220
39 kΩ	7	13	100
	10	21	160
	14	26	160
	20	32	150
15 kΩ	7	11	30
	10	17,5	50
	14	24	50
	20	28,5	50

NOTE 1 : Time from negative edge of input signal (Pin 7) to negative edge of gate voltage (Pin 4) measured at 5V threshold.

NOTE 2 : Gate discharge time, not LOAD switching OFF time.

NOTE 3 : TMOS used is Motorola MTP50N06, load 10Ω resistor.

Reverse Battery

The device does not sustain reverse battery operation for Vcc voltage greater than - 0,6V in magnitude. In application, pin 5 should be protected from reverse battery by connecting a diode in series with the V_{bat} line.

Figure15.

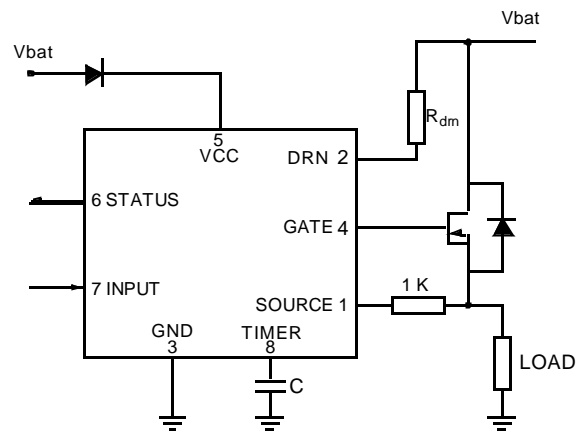

Pin 2 which is normally connected to resistor, can sustain reverse battery operation, providing that the DRN resistor is higher than 3,3K. A 1K resistor at pin 1 is also necessary to limit the reverse current flowing through the MOSFET body diode.

Figure16. MC33198 Gnd Disconnection Circuitry

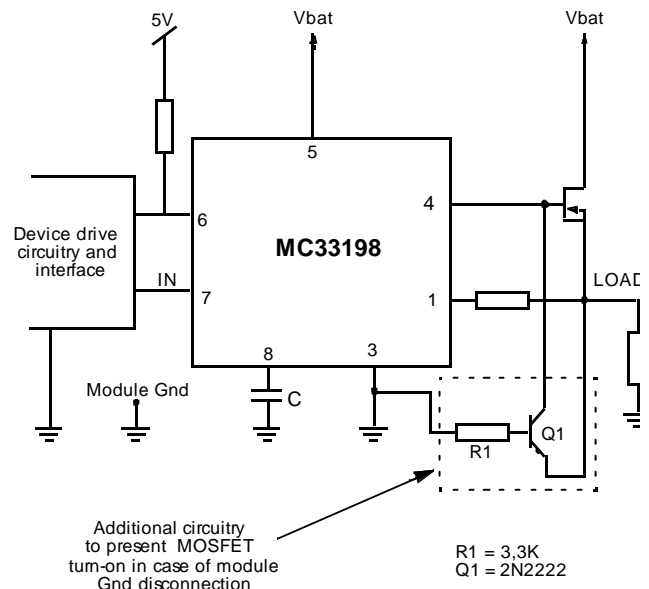

Operation

When module Gnd is disconnected and if VBAT connection is still present, pin 3 of MC33198 goes to about 2/3 of V_{bat} if additional circuitry is not inserted.

With R1/Q1, Gate/Source voltage of MOSFET is shorted as soon as pin 3 voltage rises above Gnd level.

MC33091A AND MC33198D COMPARISON

Introduction

The MC33091A and MC33198D are Motorola integrated circuits designed to control power MOSFET devices in high side switching applications. A brief comparison of both devices is presented to help the user select the right device for the application. For a detailed description of the MC33091A, please refer to the MC33091A data sheet.

General Comparison

Both devices are pin-to-pin compatible. The MC33091A has a stand-by mode activated when ever the Input (pin 7) is in the low state.

In this case, the supply current is less than 300 μ A over $7.0V \leq VCC \leq 24V$ and $-40^{\circ}C \leq \text{Ambient Temperature} \leq 125^{\circ}C$. The MC33198D does not have as low a stand-by supply current feature. It's circuitry is always powered up, causing the device to have a higher stand-by current but capable of faster switching making it more suitable for applications requiring higher Pulse-Width-Modulation frequencies.

In addition, the MC33198D can sense and report the output load voltage status in both Input states. This feature can be used to monitor the load when the MOSFET is off; for example, when checking for a short to Supply.

MOSFET Protection Features

In case of a MOSFET over current condition, the MC33091A detects the fault and rapidly turns-off the MOSFET, thus protecting the external MOSFET and its load. The MC33091A automatically attempts to re-energize the MOSFET so long as the over current condition exists. The faulted condition duty cycle is determined by the external components of the MC33091A and over current conditions.

The MC33091A monitors the Drain-to-Source voltage developed across the MOSFET; the developed voltage produces a squared current out of pin 8 proportional to the voltage. The squared current best images the power

dissipation of the MOSFET and gives a most accurately tracks the power dissipation. The produced squared current determines the charge present on a parallel resistor capacitor network. The capacitor voltage is monitored and compared to internal thresholds to cause turn-off and allow turn-on of the MOSFET. A shorted load condition will produce a large Drain-to-Source voltage to be developed across the MOSFET, causing a large pin 8 current to be produced causing the resistor capacitor network voltage to rise to the a high value exceeding the threshold level, causing MC33091A to rapidly turn-off the external MOSFET and thus protect the MOSFET from catastrophic failure.

The MC33198D feature differs in that the Drain-to-Source voltage developed across the MOSFET is compared to the voltage present at pin 2. The voltage at pin 2 is created by the internal reference current and the resistor connected to pin 2 in sensing the Drain voltage. If the Drain-to-Source voltage is higher than pin 2 voltage, the device will charge the timing capacitor connected to pin 8 until the capacitor reaches the internal threshold, then latched off the MOSFET. The MC33198D will set the fault and keep the MOSFET latched-off until the input is switched low (off) and turned back on again.

Fault Status

Both devices report the fault status to the microcontroller via pin 6. The MC33091A fault pin is not valid when pin 7 is in low state, while the MC33198D fault status is valid in both low and high states of pin 7.

Power Supply

Both devices are powered from the battery line. Both devices have an overvoltage shutdown greater than 20V.

The MC33198D incorporates an undervoltage shutdown feature which switches off the MOSFET for battery voltages less than 7V.

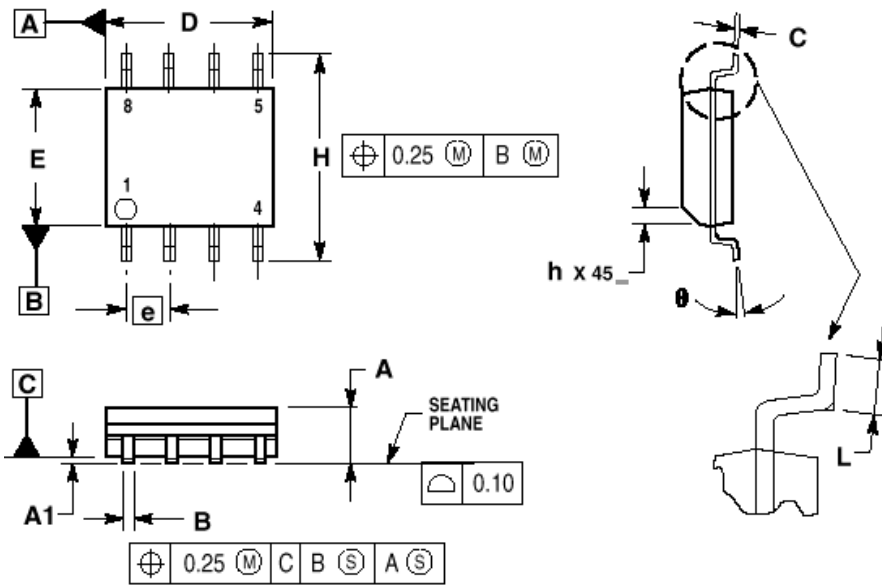

NOTES:

1. DIMENSIONING AND TOLERANCING PER ASME Y14.5M, 1994.
2. DIMENSIONS ARE IN MILLIMETER.
3. DIMENSION D AND E DO NOT INCLUDE MOLD PROTRUSION.
4. MAXIMUM MOLD PROTRUSION 0.15 PER SIDE.
5. DIMENSION B DOES NOT INCLUDE DAMBAR PROTRUSION. ALLOWABLE DAMBAR PROTRUSION SHALL BE 0.127 TOTAL IN EXCESS OF THE B DIMENSION AT MAXIMUM MATERIAL CONDITION.

DIM	MILLIMETERS	
	MIN	MAX
A	1.35	1.75
A1	0.10	0.25
B	0.35	0.49
C	0.19	0.25
D	4.80	5.00
E	3.80	4.00
e	1.27 BSC	
H	5.80	6.20
h	0.25	0.50
L	0.40	1.25
θ	0	7

Motorola reserves the right to make changes without further notice to any products herein to improve reliability, function or design. Motorola does not assume any liability arising out of the application or use of any product or circuit described herein ; neither does it convert any licence under its patent rights of others. Motorola products are not authorized for use as components in life support devices or systems intended for surgical implant into the body or intended to support or sustain life. Buyer agrees to notify Motorola of any such intended end use whereupon Motorola shall determine availability and suitability of its products for the use intended. Motorola and  are registered trademarks of Motorola, Inc. Motorola, Inc. is an Equal Employment opportunity/Affirmative Action Employer.

SUNSTAR 商斯达实业集团是集研发、生产、工程、销售、代理经销、技术咨询、信息服务等为一体的高科技企业，是专业高科技电子产品生产厂家，是具有 10 多年历史的专业电子元器件供应商，是中国最早和最大的仓储式连锁规模经营大型综合电子零部件代理分销商之一，是一家专业代理和分销世界各大品牌 IC 芯片和电子元器件的连锁经营综合性国际公司，专业经营进口、国产名厂名牌电子元件，型号、种类齐全。在香港、北京、深圳、上海、西安、成都等全国主要电子市场设有直属分公司和产品展示展销窗口门市部专卖店及代理分销商，已在全国范围内建成强大统一的供货和代理分销网络。我们专业代理经销、开发生产电子元器件、集成电路、传感器、微波光电元器件、工控机/DOC/DOM 电子盘、专用电路、单片机开发、MCU/DSP/ARM/FPGA 软件硬件、二极管、三极管、模块等，是您可靠的一站式现货配套供应商、方案提供商、部件功能模块开发配套商。商斯达实业公司拥有庞大的资料库，有数位毕业于著名高校——有中国电子工业摇篮之称的西安电子科技大学（西军电）并长期从事国防尖端科技研究的高级工程师为您精挑细选、量身订做各种高科技电子元器件，并解决各种技术问题。

更多产品请看本公司产品专用销售网站：

商斯达中国传感器科技信息网：<http://www.sensor-ic.com/>

商斯达工控安防网：<http://www.pc-ps.net/>

商斯达电子元器件网：<http://www.sunstare.com/>

商斯达微波光电产品网：[HTTP://www.rfoe.net/](http://www.rfoe.net/)

商斯达消费电子产品网：<http://www.icasic.com/>

商斯达实业科技产品网：<http://www.sunstars.cn/>

传感器销售热线：

地址：深圳市福田区福华路福庆街鸿图大厦 1602 室

电话：0755-83370250 83376489 83376549 83607652 83370251 82500323

传真：0755-83376182 (0) 13902971329 MSN: SUNS8888@hotmail.com

邮编：518033 E-mail:szss20@163.com QQ: 195847376

深圳赛格展销部：深圳华强北路赛格电子市场 2583 号 电话：0755-83665529 25059422

技术支持：0755-83394033 13501568376

欢迎索取免费详细资料、设计指南和光盘；产品凡多，未能尽录，欢迎来电查询。

北京分公司：北京海淀区知春路 132 号中发电子大厦 3097 号

TEL: 010-81159046 82615020 13501189838 FAX: 010-62543996

上海分公司：上海市北京东路 668 号上海赛格电子市场 2B35 号

TEL: 021-28311762 56703037 13701955389 FAX: 021-56703037

西安分公司：西安高新开发区 20 所(中国电子科技集团导航技术研究所)

西安劳动南路 88 号电子商城二楼 D23 号

TEL: 029-81022619 13072977981 FAX:029-88789382